



WARRANTY REPAIR CLAIM FORM - AUTOMOTIVE

CUSTOMER INFORMATION

Name _____
 Address _____
 City/State/Zip _____
 Phone (Day) _____
 Phone (Evenings) _____

WARRANTY SERVICING DEALER INFORMATION

Owner/Manager _____
 DBA _____
 Address _____
 City/State/Zip _____
 Phone _____ Fax _____

VEHICLE & DEFECTIVE FILM INFORMATION

Year _____ Make _____ Model _____ 2-Door 3-Door 4-Door
 Original Film Installation Date _____ Original Film Installation Fee _____ 5-Door 6-Door

PRODUCT FAILURE DESCRIPTION - Describe The Film Defect (peeling, cracking, bubbling etc.)

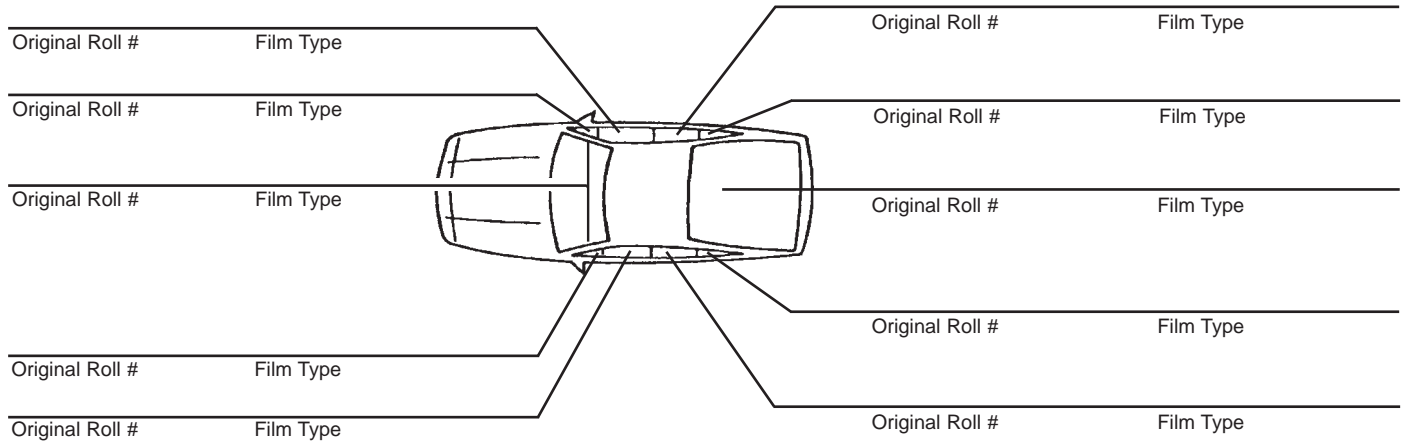

NEW FILM WARRANTY REPAIR INFORMATION

New Film Type _____ Warranty Repair Service Date _____
 New Film Type _____ New Film Roll # _____
 New Film Type _____ New Film Roll # _____

JOB COMPLETION CERTIFICATION

Submit this completed form with a copy of the customer's warranty, original invoice, redo invoice and a 1 square foot sample of the defective film within 6 months after the warranty work has been performed.

I hereby certify the warranty repair claim as described above is legitimate, also understand that a fraudulent warranty claim could constitute legal action by Bekaert Specialty Films, LLC. The work has been completed and all parties have been satisfied.

Customer Signature _____ Date _____ Dealer Signature _____ Date _____

FOR BSF USE ONLY		Film Claim Payment			Labor Claim Payment			Total Claim
Film Type	Roll #	Sq. Ft.	\$ Per Sq. Ft.	Total	Sq. Ft.	\$ Per Sq. Ft.	Total	Payment